

BARRIER WASHER EXTRACTORS

NEW EASY TOUCH MICROPROCESSOR

MEDII 16
MEDII 22

FEATURES

- High spin soft mounted washer extractor, no need of anchorage, 2 opposed doors.
- Extraction speed 1000 RPM.
- G force 361.
- Horizontally suspended drum by means of two axles which increase robustness, 1 compartment.
- Electric or steam heating.
- New EASY TOUCH microprocessor with a lot of devices for a greater flexibility.
- 26 preset programs, unlimited creation of new programs.
- Wet Cleaning system integrated (standard).
- Standard double display.
- Optimal load system integrated: manual indication of load.
- Capacity 16 and 22 kg.
- Body, drum and vat in stainless steel.
- Soap dispenser with 4 compartments.
- Three water inlets standard in all range.
- 8 signals for liquid dosing.
- Out of balance detection by means of the inverter.
- Traceability - storage of data.



OPTIONS

- 2nd drain valve.
- Central position drain valve.
- Titration valve
- Automatic Weighing sensor System on feet.
- Drum Electric brake.
- Relay card to increase up to 14 signals for liquid dosing.
- Lighting column at the end of cycle.
- Dual heating electric and steam.
- Plinth up to height 850 mm from door bottom.
- Stainless steel wall frame with rubber



Charge optimale



Inox



Eau chaude
et Eau froide



Inverter



3 arrivées d'eau



Charge optimale



Installation et
maintenance aisées



Wet cleaning



Pesage

TECHNICAL DATA	UNIT.	MEDII 16	MEDII 22
DRUM			
Capacity 1:9 / 1:10	Kg	18 / 16	25 / 22
Volume	l	158	220
Diameter	mm	633	633
Depth	mm	500	700
Number of compartments	N°.	1	1
GENERAL DETAILS			
Washing speed / Spining speed	r.p.m.	45 / 1000	45 / 1000
G Force	-	361	361
Easy Touch Microprocessor	-	Standard	Standard
Double drain	-	Option	Option
DOORS			
Drum doors dimensions	mm	400 x 315	400 x 315
Vat doors dimensions	mm	455 x 415	455 x 415
Height base door	mm	670	670
POWER			
Motor	kW	2.2	2.2
Electric heating	kW	12	18
Max. power (electric heating)	kW	14.2	20.2
Max. power (hot water model)	kW	2.2	2.2
Max. power (steam model)	kW	2.2	2.2
CONNECTIONS			
Water inlets	inch	3/4	3/4
Steam inlet	inch	3/4	3/4
Drain	mm/inch	80 / 3"	80 / 3"
MACHINE DIMENSIONS / PACKING DIMENSIONS			
Length / Length	mm	980 / 1.072	1180 / 1.262
Width / Width	mm	910 / 1.102	910 / 1.102
Height / Height	mm	1400 / 1.394	1400 / 1.394
Net weight / Gross weight	kg	438 / 459	471 / 494
Volume	m ³	1.65	1.94

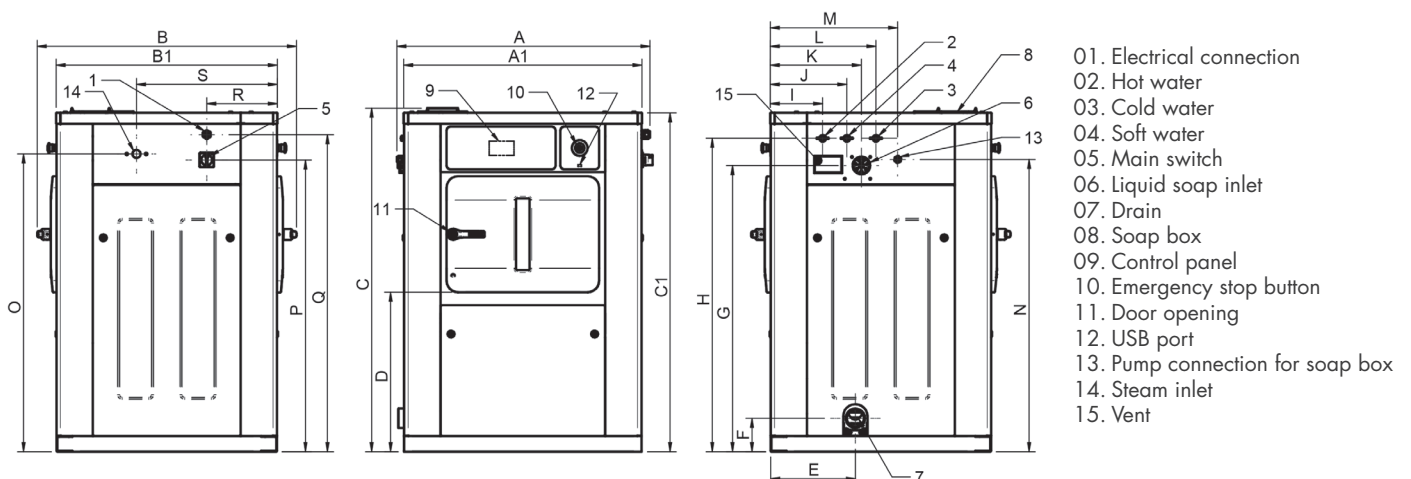

	A	B	C	A1	B1	C1	D	E	F	G	H	I	J	K	L	M	N	O	P	Q	R	S
MEDII 16	1045	1071	1417	984	914	1398	658	350	138	1180	1292	216	316	377	436	527	1205	1228	1203	1308	292	582
MEDII 22	1245	1071	1417	1184	914	1398	658	350	138	1180	1292	216	316	377	436	527	1205	1228	1203	1308	292	582