

BARRIER WASHER EXTRACTORS

NEW EASY TOUCH MICROPROCESSOR

MEDII 35

FEATURES

- High spin soft mounted washer extractor, no need of anchorage, 2 opposed doors.
- Extraction speed 1000 RPM.
- G force 448.
- Horizontally suspended drum by means of 2 axes which increase robustness, 1 compartment.
- Electric or steam heating.
- New EASY TOUCH microprocessor with Touch Screen and a lot of devices for a greater flexibility.
- 26 preset programs, unlimited creation of new pro-grams.
- WET CLEANING system integrated (standard).
- Standard double display.
- OPTIMAL LOAD system integrated: manual indication of the load.
- 3 water inlets standard.
- Capacity 33 kg.
- Body, drum and vat in stainless steel.
- Soap dispenser with 4 compartments.
- 8 signals for dosing pumps.
- Out of balance detection by means of the inverter.
- Traceability - data storage integrated.



OPTIONS

- 2nd drain valve.
- Central position of drain valve.
- Titration valve.
- Automatic weighing sensor system on feet.
- Drum electric brake.
- Relay card to increase up to 14 signals for dosing pumps.
- Plinth up to 850 mm loading height from door bottom.
- Stainless steel wall frame with rubber.
- Lighting column at the end of cycle.
- Dual heating electric - steam.



Charge optimale



Inox



Eau chaude
et Eau froide



Inverter



3 arrivées d'eau



Charge optimale



Installation et
maintenance aisées



Wet cleaning



Pesage

TECHNICAL DATA	UNIT.	MEDII 35
DRUM		
Capacity 1:9 / 1:10	Kg	37 / 33
Volume	l	330
Diameter	mm	800
Depth	mm	654
Number of compartments	N°.	1
GENERAL DETAILS		
Washing speed / Spining speed	r.p.m.	45 / 1000
G Force	-	448
Easy Touch Microprocessor	-	Standard
Double drain	-	Option
DOORS		
Drum doors dimensions	mm	450 x 320
Vat doors dimensions	mm	510 x 460
Height base door	mm	776
POWER		
Motor	kW	4
Electric heating	kW	27
Max. power (electric heating)	kW	31
Max. power (hot water model)	kW	4
Max. power (steam model)	kW	4
CONNECTIONS		
Water inlets	inch	3/4
Steam inlet	inch	3/4
Drain	mm/inch	80 / 3"
MACHINE DIMENSIONS / PACKING DIMENSIONS		
Length / Length	mm	1.276 / 1.452
Width / Width	mm	1.056 / 1.222
Height / Height	mm	1.580 / 1.694
Net weight / Gross weight	kg	748 / 780
Volume	m ³	3.01

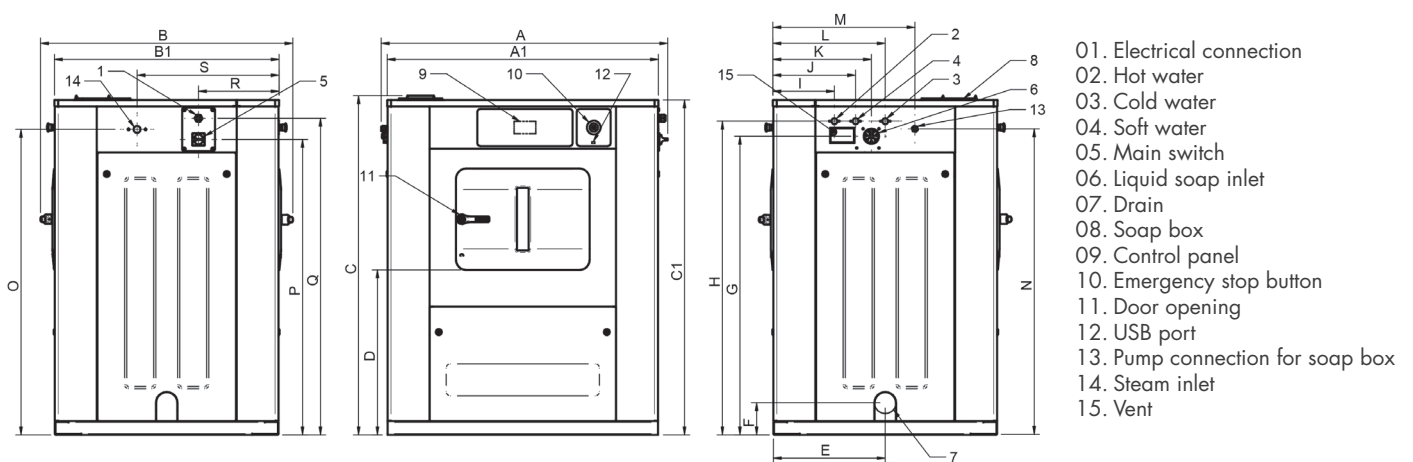

	A	B	C	A1	B1	C1	D	E	F	G	H	I	J	K	L	M	N	O	P	Q	R	S
MEDII 35	1352	1191	1601	1280	1060	1580	778	528	152	1409	1480	290	390	465	530	670	1441	1441	1394	1494	380	670