

BARRIER WASHER EXTRACTORS

NEW EASY TOUCH MICROPROCESSOR

MEDII 66

FEATURES

- High spin soft mounted washer extractor, no need of anchorage, 2 opposed doors.
- Extraction speed 900 RPM.
- G force 360
- Horizontally suspended drum by means of 2 axles which increase robustness, 2 compartments.
- Electric or steam heating.
- New EASY TOUCH microprocessor with Touch Screen and a lot of devices for a greater flexibility.
- 26 preset programs, unlimited creation of new programs.
- WET CLEANING system integrated (standard).
- Standard double display.
- OPTIMAL LOAD system integrated: manual indication of the load.
- 3 water inlets standard.
- Capacity 67 kg.
- Body, drum and vat in stainless steel.
- Soap dispenser with 4 compartments.
- 8 signals for dosing pumps.
- Out of balance detection by means of the inverter.
- Traceability - data storage integrated.



model with vertical opening door

OPTIONS

- 2nd drain valve.
- Central position of drain valve.
- Titration valve.
- Automatic weighing sensor system on feet.
- Drum electric brake.
- Relay card to increase up to 14 signals for dosing pumps.
- Plinth up to 850 mm loading height from door bottom.
- Stainless steel wall frame with rubber.
- Lighting column at the end of cycle.
- Dual heating electric - steam.
- Vertical opening of door instead of the lateral one of both doors.



Charge optimale



Inox



Eau chaude et Eau froide



Inverter



3 arrivées d'eau



Charge optimale



Installation et maintenance aisées



Wet cleaning



Pesage

TECHNICAL DATA	UNIT.	MEDII 66
DRUM		
Capacity 1:9 / 1:10	Kg	74 / 67
Volume	l	667
Diameter	mm	800
Depth	mm	1.327
Number of compartments	N°.	2
GENERAL DETAILS		
Washing speed / Spining speed	r.p.m.	45 / 900
G Force	-	360
Easy Touch Microprocessor	-	Standard
Double drain	-	Option
DOORS		
Drum doors dimensions	mm	450 x 320
Vat doors dimensions	mm	510 x 460 (x2)
Height base door	mm	798
POWER		
Motor	kW	7.5
Electric heating	kW	45
Max. power (electric heating)	kW	52.5
Max. power (hot water model)	kW	7.5
Max. power (steam model)	kW	7.5
CONNECTIONS		
Water inlets	inch	1
Steam inlet	inch	3/4
Drain	mm/inch	80 / 3"
MACHINE DIMENSIONS / PACKING DIMENSIONS		
Length / Length	mm	1.949 / 2.102
Width / Width	mm	1.056 / 1.222
Height / Height	mm	1.660 / 1.694
Net weight / Gross weight	kg	1.233 / 1.275
Volume	m ³	4.35

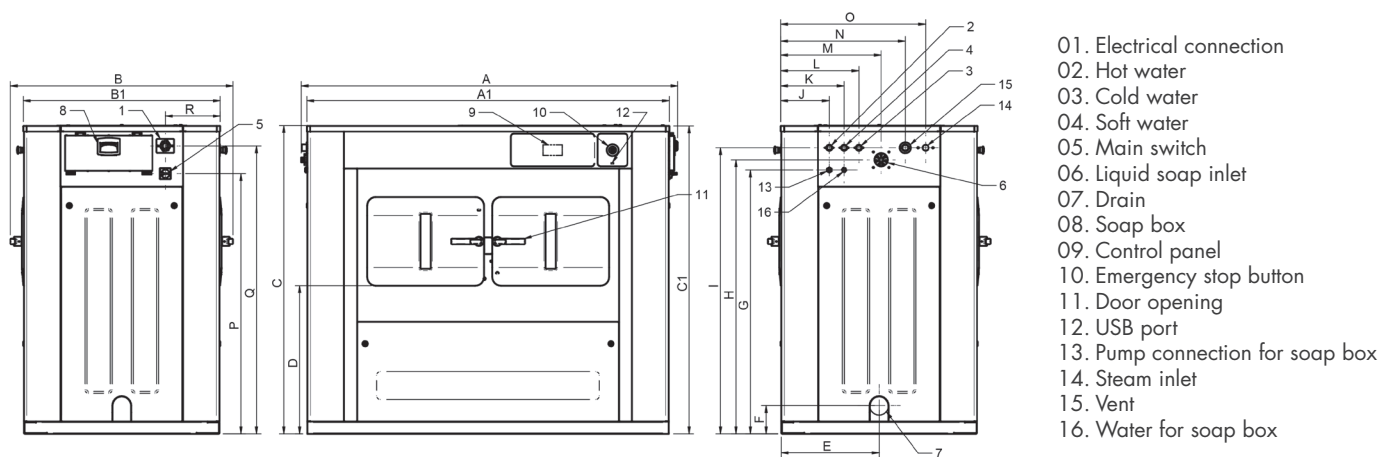

	A	B	C	A1	B1	C1	D	E	F	G	H	I	J	K	L	M	N	O	P	Q	R	S
MEDII 66	2032	1201	1662	1955	1062	1660	798	528	152	1423	1478	1543	262	342	422	542	672	782	1403	1553	296	-